

Specifications

MODELS	GS™-1530		GS™-1930	
MEASUREMENTS	US	Metric	US	Metric
Working height maximum*	21 ft	6.57 m	25 ft	7.79 m
● Platform height maximum	15 ft	4.57 m	19 ft	5.79 m
● Platform length - outside	5 ft 4 in	1.63 m	5 ft 4 in	1.63 m
extended	8 ft 4 in	2.54 m	8 ft 4 in	2.54 m
Slide-out platform extension deck	3 ft	.91 m	3 ft	.91 m
● Platform width - outside	2 ft 5 in	.74 m	2 ft 5 in	.74 m
Guardrail height: ANSI, CSA, AUS	3 ft 3 in	.99 m	3 ft 3 in	.99 m
CE	3 ft 7 in	1.10 m	3 ft 7 in	1.10 m
Toeboard height	6 in	.15 m	6 in	.15 m
● Height - stowed: fixed rails	6 ft 5 in	1.96 m	6 ft 7 in	2.00 m
folding guardrails	6 ft 8 in	2.03 m	6 ft 11 in	2.11 m
rails folded	5 ft 8 in	1.73 m	5 ft 9 in	1.75 m
● Length - stowed	6 ft	1.83 m	6 ft	1.83 m
Length - stowed extended	9 ft	2.74 m	9 ft	2.74 m
● Width	2 ft 6 in	.76 m	2 ft 6 in	.76 m
● Wheelbase	4 ft 4 in	1.32 m	4 ft 4 in	1.32 m
● Ground clearance - center	2.4 in	.06 m	2.4 in	.06 m
● - with pothole guards deployed	.75 in	.02 m	.75 in	.02 m

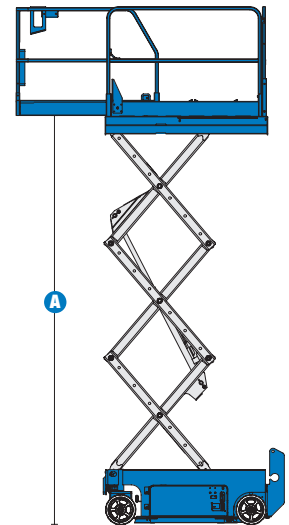
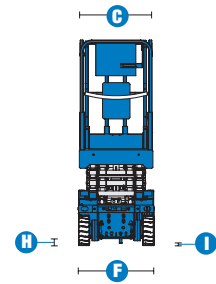
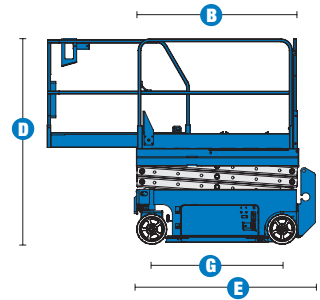

PRODUCTIVITY				
Lift capacity	600 lbs	272 kg	500 lbs	227 kg
Lift capacity - extension deck	250 lbs	113 kg	250 lbs	113 kg
Drive speed - stowed	2.5 mph	4.0 km/h	2.5 mph	4.0 km/h
Drive speed - raised	0.5 mph	0.8 km/h	0.5 mph	0.8 km/h
Gradeability - stowed**	30%		30%	
Turning radius - inside	zero	zero	zero	zero
Turning radius - outside	5 ft 1 in	1.55 m	5 ft 1 in	1.55 m
Raise / lower speed	16 / 17 sec	16 / 17 sec	16 / 23 sec	16 / 23 sec
Controls	proportional		proportional	
Drive	dual front wheel		dual front wheel	
Multiple disc brakes	dual rear wheel		dual rear wheel	
Tires - solid non-marking	12 x 4.5 x 8 in	30 x 11 x 20 cm	12 x 4.5 x 8 in	30 x 11 x 20 cm

POWER				
Power source	24 V (four 6 V 225 Ah batteries)		24 V (four 6 V 225 Ah batteries)	
Hydraulic system capacity	5.5 gal	20.8 L	5.5 gal	20.8 L

WEIGHT***				
ANSI, CSA	2,575 lbs	1,168 kg	2,702 lbs	1,226 kg
CE indoor	2,718 lbs	1,233 kg	3,302 lbs	1,498 kg
AUS indoor	—	—	3,302 lbs	1,498 kg

STANDARDS COMPLIANCE	ANSI A92.6, CSA B354.2, CE Compliance, AS 1418.10, PB-10-611-03
----------------------	---

* The metric equivalent of working height adds 2 m to platform height. U.S. adds 6 ft to platform height.
 ** Gradeability applies to driving on slopes, see operator's manual for details regarding slope ratings.
 *** Weight will vary depending on options and/or country standards.

Features

STANDARD FEATURES

MEASUREMENTS

GS™-1530

- 21 ft (6.57 m) working height
- Up to 600 lb (272 kg) lift capacity

GS™-1930

- 25 ft (7.79 m) working height
- Up to 500 lb (227 kg) lift capacity

PRODUCTIVITY

- Steel 5 ft 4 in (1.63 m) platform
- Fixed rail with chain entry gate
- 3 ft (.91 m) extension deck
- 2WD
- Proportional lift and drive
- 30% gradeability
- Onboard diagnostic system
- AC power to platform
- Manual platform lowering valve
- Emergency stop at both platform and ground controls
- Multiple disc brakes
- Brake release
- Solid non-marking tires
- Pothole guards
- Tilt level sensor with audible alarm
- Descent alarm
- Electronic horn
- Hour meter

POWER

- 24V (four 6V 225 Ah batteries)
- Automatic battery charger

OPTIONS & ACCESSORIES

PRODUCTIVITY

- Folding rails with half-height swing gate
- Platform swing gate, half-height
- Air line to platform
- Dual flashing beacons
- Motion package
- Platform work lights
- Ground controls cover
- Automotive horn

POWER

- Power inverter
- Maintenance-free batteries
- EE rating

